

TRAILING EDGE PRODUCT - MINIMUM ORDER APPLIES



Elm Road, West Chirton Industrial Estate, North Shields,
NE29 8SE, ENGLAND. TEL +44 (0191) 2930500. FAX +44 (0191)
2590997

2M x 8 SRAM MODULE

SYS82000FKX - 70/85/10/12

Issue 2.5 : February 2000

Description

The SYS82000FKX is a plastic 16Mbit Static RAM Module housed in a JEDEC standard 36 pin Dual In-Line package organised as 2Mx8.

The module utilises 512Kx8 SRAM's housed in TSOPII packages, and uses double sided surface mount techniques, buried decoder and dual board construction to achieve a very high density module, emulating the 16Mbit monolithic pinout.

Access times of 70 to 120 ns are available. The \overline{OE} pin allows faster access times than address access during a read cycle.

Features

- Access Times of 70/85/100/120 ns.
- 36 Pin JEDEC standard Dual-In-Line package.
- 5 Volt Supply $\pm 10\%$.
- Center Power and Ground Pinout.
- Low Power Dissipation:
Average (min cycle) 600mW (max).
Standby 26.4mW (max).
- Low Voltage V_{CC} Data Retention.
- Equal Access and Cycle Times.
- Directly TTL Compatible.
- On-board Supply Decoupling Capacitors.

Block Diagram

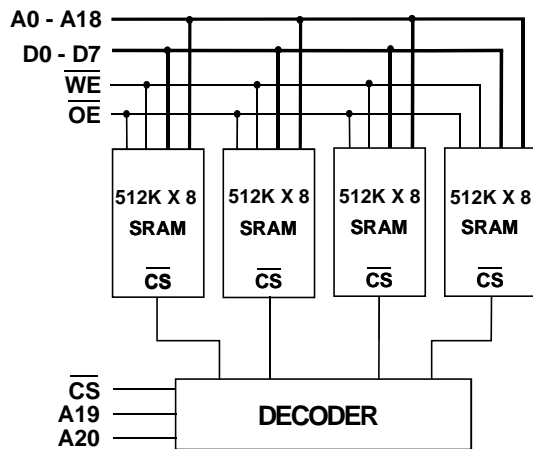

Pin Definition

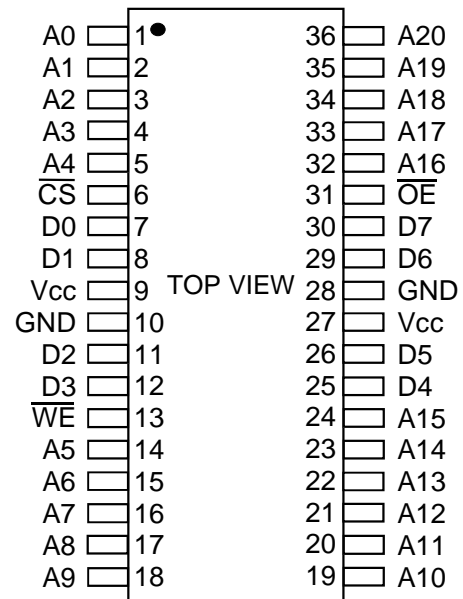

Pin Functions

Address Inputs	A0 - A20
Data Input/Output	D0 - D7
Chip Select	\overline{CS}
Write Enable	\overline{WE}
Output Enable	\overline{OE}
Power (+5V)	V_{CC}
Ground	GND

Package Details

Plastic 36 Pin 0.6" Dual-In-Line low profile Package.(DIP)

DC OPERATING CONDITIONS**Absolute Maximum Ratings** ⁽¹⁾

Parameter	Symbol	Min	Typ	Max	Unit
Voltage on any pin relative to V_{SS}	$V_T^{(2)}$	-0.3	-	7.0	V
Power Dissipation	P_T	-	1.0	-	W
Storage Temperature	T_{STG}	-55	-	125	°C

Notes : (1) Stresses above those listed may cause permanent damage to the device. This is a stress rating only and functional operation of the device at those or any other conditions above those indicated in the operational sections of this specification is not implied. Exposure to absolute maximum rating conditions for extended periods may affect device reliability.

(2) V_T can be -3.0V pulse of less than 30ns.

Recommended Operating Conditions

Parameter	Symbol	Min	Typ	Max	Unit
Supply Voltage	V_{CC}	4.5	5.0	5.5	V
Input High Voltage	V_{IH}	2.2	-	$V_{CC}+0.3$	V
Input Low Voltage	V_{IL}	-0.3	-	0.8	V
Operating Temperature (Commercial)	T_A	0	-	70	°C
(Industrial)	T_{AI}	-40	-	85	°C

DC Electrical Characteristics $(V_{CC}=5V\pm 10\%)$ T_A 0 to 70 °C

Parameter	Symbol	Test Condition	Min	Typ	max	Unit	
I/P Leakage Current Address, \overline{OE} , \overline{WE}	I_{LI}	$0V \leq V_{IN} \leq V_{CC}$	-5	-	5	μA	
Output Leakage Current	I_{LO}	$\overline{CS} = V_{IH}$, $V_{IO} = GND$ to V_{CC} , $\overline{OE} = V_{IH}$	-5	-	5	μA	
Operating Supply Current	I_{CC1}	Min. Cycle, $\overline{CS} = V_{IL}$, $V_{IL} \leq V_{IN} \leq V_{IH}$	-	-	109	mA	
Standby Supply Current	I_{SB1}	TTL levels	-	-	12	mA	
		CMOS levels	$\overline{CS} \geq V_{CC} - 0.2V$, $0.2 \leq V_{IN} \leq V_{CC} - 0.2V$	-	-	480	μA
		-L Version (CMOS)	$\overline{CS} \geq V_{CC} - 0.2V$, $0.2 \leq V_{IN} \leq V_{CC} - 0.2V$	-	-	280	μA
Output Voltage	V_{OL}	$I_{OL} = 2.1mA$	-	-	0.4	V	
	V_{OH}	$I_{OH} = -1.0mA$	2.4	-	-	V	

Typical values are at $V_{CC}=5.0V$, $T_A=25^\circ C$ and specified loading.

Capacitance ($V_{CC}=5V\pm 10\%$, $T_A=25^\circ C$)

Note: Capacitance calculated, not measured.

Parameter	Symbol	Test Condition	max	Unit
Input Capacitance (Address, \overline{OE} , \overline{WE})	C_{IN1}	$V_{IN} = 0V$	38	pF
I/P Capacitance (other)	C_{IN2}	$V_{IN} = 0V$	10	pF
I/O Capacitance	C_{IO}	$V_{IO} = 0V$	32	pF

AC Test Conditions**Output Load**

- * Input pulse levels: 0V to 3.0V
- * Input rise and fall times: 5ns
- * Input and Output timing reference levels: 1.5V
- * Output load: see diagram
- * $V_{CC}=5V\pm 10\%$

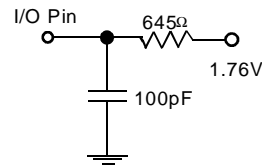
**Operation Truth Table**

\overline{CS}	\overline{OE}	\overline{WE}	DATA PINS	SUPPLY CURRENT	MODE
H	X	X	High Impedance	$I_{SB1}, I_{SB2}, I_{SB3}$	Standby
L	L	H	Data Out	I_{CC1}	Read
L	H	L	Data In	I_{CC1}	Write
L	L	L	Data In	I_{CC1}	Write
L	H	H	High-Impedance	$I_{SB1}, I_{SB2}, I_{SB3}$	High-Z

Notes : H = V_{IH} : L = V_{IL} : X = V_{IH} or V_{IL}

Low V_{CC} Data Retention Characteristics - L Version Only

Parameter	Symbol	Test Condition	min	typ ⁽¹⁾	max	Unit
V_{CC} for Data Retention	V_{DR}	$\overline{CS} \geq V_{CC}-0.2V$	2.0	-	-	V
Data Retention Current	I_{CCDR1}	$2.0 \leq V_{CC} \leq 5.5V, \overline{CS} \geq V_{CC}-0.2$	-	-	280	μA
Chip Deselect to Data Retention Time	t_{CDR}	See Retention Waveform	0	-	-	ns
Operation Recovery Time	t_R	See Retention Waveform	5	-	-	ms

- Notes (1) Typical figures are measured at 25°C.
 (2) This parameter is guaranteed not tested.

AC OPERATING CONDITIONS**Read Cycle**

Parameter	Symbol	-70		-85		-10		-12		Unit
		min	max	min	max	min	max	min	max	
Read Cycle Time	t_{RC}	70	-	85	-	100	-	120	-	ns
Address Access Time	t_{AA}	-	70	-	85	-	100	-	120	ns
Chip Select Access Time	t_{ACS}	-	70	-	85	-	100	-	120	ns
Output Enable to Output Valid	t_{OE}	-	40	-	45	-	50	-	55	ns
Output Hold from Address Change	t_{OH}	10	-	10	-	10	-	10	-	ns
Chip Selection to Output in Low Z	t_{CLZ}	10	-	10	-	10	-	10	-	ns
Output Enable to Output in Low Z	t_{OLZ}	5	-	5	-	5	-	5	-	ns
Chip Deselection to O/P in High Z	t_{CHZ}	0	25	0	30	0	35	0	40	ns
Output Disable to Output in High Z	t_{OHZ}	0	25	0	30	0	35	0	40	ns

Write Cycle

Parameter	Symbol	-70		-85		-10		-12		Unit
		min	max	min	max	min	max	min	max	
Write Cycle Time	t_{WC}	70	-	85	-	100	-	120	-	ns
Chip Selection to End of Write	t_{CW}	60	-	70	-	80	-	100	-	ns
Address Valid to End of Write	t_{AW}	60	-	70	-	85	-	100	-	ns
Address Setup Time	t_{AS}	0	-	0	-	0	-	0	-	ns
Write Pulse Width	t_{WP}	50	-	60	-	70	-	80	-	ns
Write Recovery Time	t_{WR}	5	-	5	-	5	-	5	-	ns
Write to Output in High Z	t_{WHZ}	0	25	0	30	0	35	0	40	ns
Data to Write Time Overlap	t_{DW}	30	-	35	-	40	-	45	-	ns
Data Hold from Write Time	t_{DH}	0	-	0	-	0	-	0	-	ns
Output active from End of Write	t_{OW}	5	-	5	-	5	-	5	-	ns

Read Cycle Timing Waveform ^(1,2)

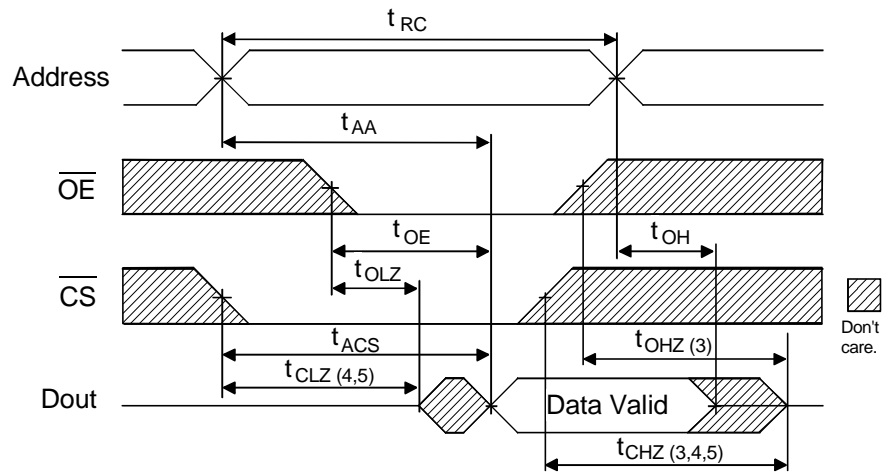

AC Read Characteristics Notes

- (1) \overline{WE} is High for Read Cycle.
- (2) All read cycle timing is referenced from the last valid address to the first transition address.
- (3) t_{CHZ} and t_{OHZ} are defined as the time at which the outputs achieve open circuit conditions and are not referenced to output voltage levels.
- (4) At any given temperature and voltage condition, t_{CHZ} (max) is less than t_{CLZ} (min) both for a given module and from module to module.
- (5) These parameters are sampled and not 100% tested.

Write Cycle No.1 Timing Waveform ^(1,4)

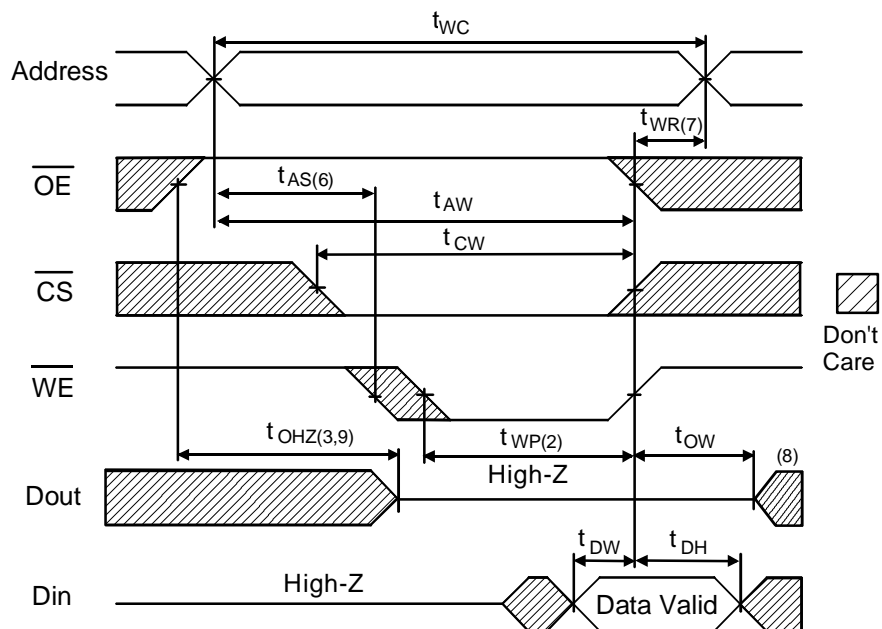

Write Cycle No.2 Timing Waveform ^(1,5)

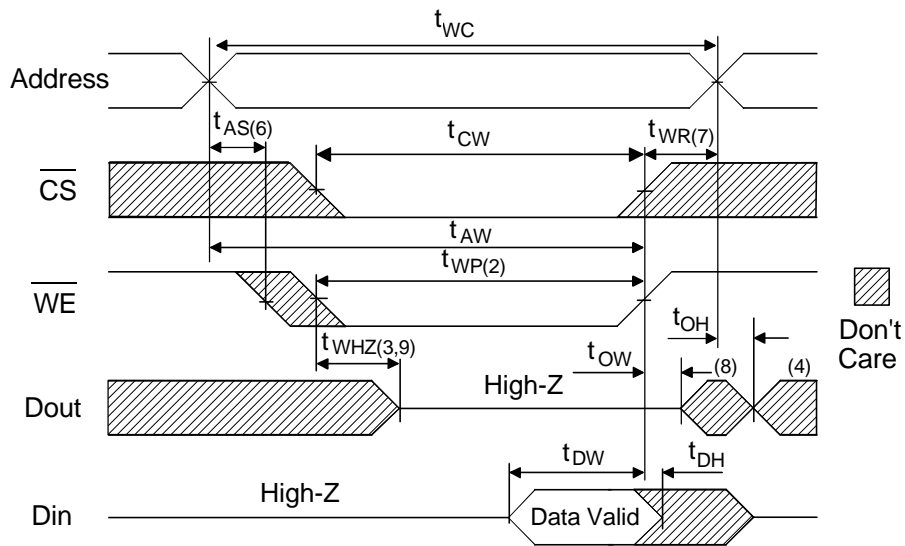

AC Write Characteristics Notes

- (1) All write cycle timing is referenced from the last valid address to the first transition address.
- (2) All writes occur during the overlap of \overline{CS} and \overline{WE} low.
- (3) If \overline{OE} , \overline{CS} , and \overline{WE} are in the Read mode during this period, the I/O pins are low impedance state. Inputs of opposite phase to the output must not be applied because bus contention can occur.
- (4) $Dout$ is the Read data of the new address.
- (5) \overline{OE} is continuously low.
- (6) Address is valid prior to or coincident with \overline{CS} and \overline{WE} low, too avoid inadvertant writes.
- (7) \overline{CS} or \overline{WE} must be high during address transitions.
- (8) When \overline{CS} is low : I/O pins are in the output state. Input signals of opposite phase leading to the output should not be applied.
- (9) Defined as the time at which the outputs achieve open circuit conditions and are not referenced to output voltage levels. These parameters are sampled and not 100% tested.

Data Retention Waveform

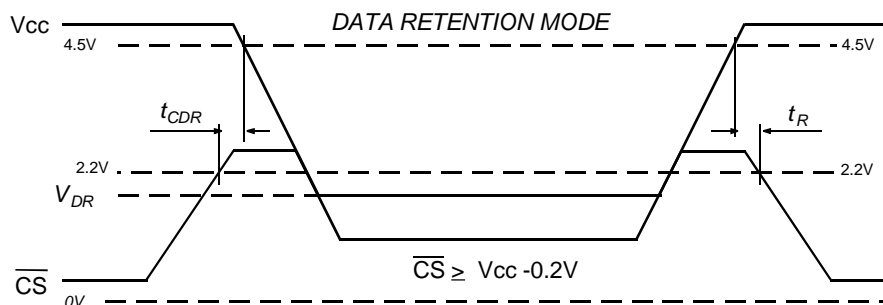

Package Information Dimensions in mm

Plastic 36 Pin 0.6" Dual-in-Line Low profile (DIP)

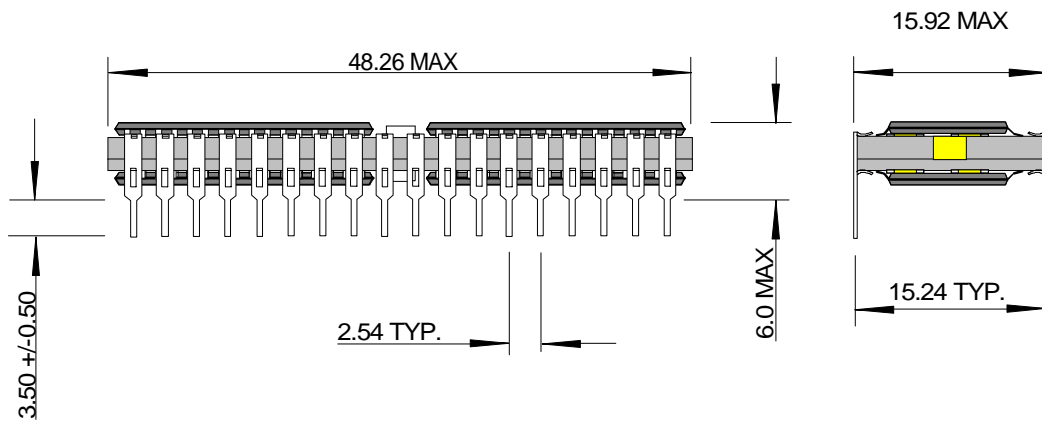

Ordering Information

SYS82000FKXLI - 70

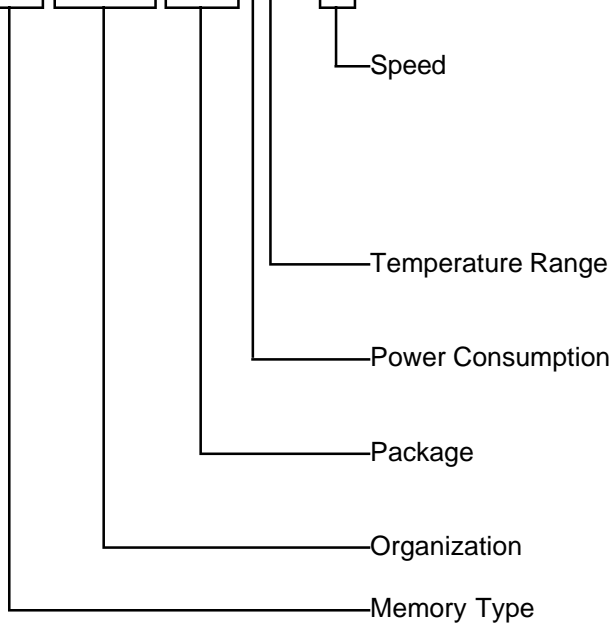

- 70 = 70 ns
- 85 = 85 ns
- 10 = 100 ns
- 12 = 120 ns

- Blank = Commercial Temperature
- I = Industrial Temperature

- Blank = Standard Part
- L = Low Power Part

- FKX = Plastic 36 Pin 0.6" Low Profile DIP

- 82000 = 2M x 8

- SYS = Static RAM

Note :

Although this data is believed to be accurate, the information contained herein is not intended to and does not create any warranty of merchantability or fitness for a particular purpose.

Our products are subject to a constant process of development. Data may be changed at any time without notice. Products are not authorised for use as critical components in life support devices without the express written approval of a company director.